

UNI-T®



UT256B

Operating Manual



200A True RMS Fork Meters



P/N: 110401105290X
DATE: 2018.06.26
REV. 1

Contents

I. Overview	1
II. OOBA (Out Of box Audit)	1
III. Safety Operation Criterion	2
IV. Electrical Symbols	4
V. Appearance Structure	5
VI. Functions of Keys	7
VII. Technical Indexes	11
1. General specifications	11
2. Environmental limit	12
3. Electric specification	12
VIII. Measurement Operation Instructions	15
1. Measuring of AC Current (ACI)	15
2. Measuring of DC Current (DCI)	17
3. Measuring of AC Voltage (ACV)	19
4. Measuring of DC Voltage (DCV)	21
5. Measurement of Resistance (OHM)	23
6. Conductivity Testing (CNT)	25
7. Diode Measurement (DIO)	27
8. Measuring of Capacitance (CAP)	29
9. Measuring of Induced Voltage (NCV)	31
IX. Maintenance and Repair	33
1. General Maintenance	33
2. The installation or replacement of batteries	33

I. Overview

UT256B is a safe and reliable AC/DC digital clamp meter in 3 5/6 digit with stable performance (hereinafter referred to as the clamp meter). The circuit design of the complete machine adopts the large scale integrated circuit Σ/Δ analog-digital converter as core, and the over-load protection circuit in the whole range and unique appearance design make it a dedicated electro-technical instrument. It is used to measure AC/DC current, AC/DC voltage, resistance, circuit on-off, diode, capacitance, etc. and meanwhile it can measure the induced voltage.

The Operation Instruction includes relevant safety information and warning, etc. Please read relevant contents carefully and strictly observe all warnings and notices.

Warning:

Before using the clamp meter, please read relevant "Safe Operation Criterion"

II. OOBA (Out Of box Audit)

Open the packing box and take out the instrument. Please carefully check whether or not the following accessories are missing or damaged.

1. Operation Instruction-----One copy
2. Probe-----One pair
3. Cloth bag-----One piece

Please contact your supplier in case of any lack or damage.

 In case of probe replacement, the probes replaced must meet the following or higher specification: double insulation CAT III 600V/CAT II 1000V 10A.

III. Safety Operation Criterion

Please pay attention to the "Warning Signs and Sentences". Warnings mean the situations and behaviors that endanger the user or cause losses to the instrument or the equipment to be measured.

The instrument is designed and produced in strict accordance with GB4793 Safety Requirements for Electronic Measuring Apparatus and IEC61010-1 and IEC61010-2-032 safety standards, and complies with the safety standard of double insulation, over-voltage CATII 1000V, CAT III 600V and pollution level 2. If you fail to use the clamp meter according to relevant operation instructions, the protection provided by the clamp meter is likely to be weakened or undermined.

Conforms to UL STD. 61010-1, 61010-2-030, 61010-2-032, 61010-2-033 Certified to CSA STD. C22.2 NO. 61010-1, 61010-2-030, IE CSTD 61010-2-032, 61010-2-033

CAT II: Applicable to test and measuring circuits connected directly to utilization points (socket outlets and similar points) of the low-voltage MAINS installation.













CAT III: Applicable to test and measuring circuits connected to the distribution part of the building's low-voltage MAINS installation, before use and follow all safety instructions.

1. Prior to using, please check the clamp meter and probe so as to prevent any damage or abnormality. If you find the probe and insulating layer of the shell

- are damaged obviously, the display screen cannot work, etc., or you consider that the clamp meter cannot work well, please don't use the clamp meter any more.
- It is strictly prohibited to use the clamp meter without the rear cover or battery cover, otherwise, shock hazard may occur.
 - When carrying out the measurement, please be sure that your fingers should not exceed the shield and not touch the bare wire and connector, unused input terminal or circuit under measurement, to prevent the electric shock.
 - Before measurement, the clamp meter must be switch to the correct tap position. It is prohibited to switch tap position during measurement, so as to prevent the clamp meter damage.
 - Do not apply DC1000V/AC750V or above voltage between the clamp meter terminal and grounding, so as to prevent electric shock and clamp meter damage.
 - When the instrument is used to measure DC voltage of higher than 42V or AC RMS voltage of higher than 30V, it is necessary to operate it carefully, for there may be danger of an electric shock.
 - Do not measure the voltage or current higher than the allowable input, and the function range switch must be placed at the maximum range position when the range of the value to be measured is not determined. Before measuring the resistance, diode or circuit on-off, it is a must to cut off all the power supplies in the circuit and discharge all capacitors, otherwise, it may lead to incorrect measurement results.

- When the symbol of “” is displayed on the LCD, it is necessary to replace the battery in a timely manner, so as to assure the measuring precision.
- Please do not change the internal wiring of the clamp meter at random, to prevent instrument damage and insecurity.
- Do not keep or use the clamp meter in an environment with high-temperature, high-humidity, inflammable, explosive or strong electromagnetic field.
- During maintenance, please clean the shell of the clamp meter with the soft cloth soaked with neutral detergent, and do not use the abradant and solvent, so as to prevent the shell corrosion, instrument damage and insecurity.
- To test the known voltage before use to confirm the product function is correct.

IV. Electrical Symbols

	Double insulation
	Grounding
	Warning
	AC (alternating current)
	DC (direct current)
	Buzzer on/off
	Diode
	Capacitance
	AC or DC (alternating current or direct current)
	Danger high voltage
	Meet European Union Standard
	This symbol signify the product comply with both USA and Canada requirement

V. Appearance Structure

1. Clamp head

It is the sensing device for AC/DC measurement. Fix the wire into the designated position to measure the current through the wire. As the head may touch the live wire at the time of the measurement, the user's hand shall be kept below the clamp head.

2. Clamp body

It is the part held by the user's hand. The user shall hold the middle of the clamp body and not exceed the protective baffle at the jointing section between the upper part of the clamp body and the clamp head; for fear that the hand touches the dangerous area.

3. Rotary knob

It is used for the start-up and selection of basic measurement functions. The salient point on rotary knob indicates the present gear position, when it points to "OFF", it means the clamp meter is off; when it points to other gears, the clamp meter will perform the corresponding measurement function.

4. Function key

It is used for the selection of key functions, including SELECT, REL/ZERO, HOLD/☼ and FLASHLIGHT.

☼ Start up or exit the corresponding key functions by the short pressing or long pressing them.

5. Display screen

It is used for the display of the measurement data and function symbols. The segment code type LCD

displays measured data, unit of corresponding function gears and symbols of key functions. The display screen also has the backlight function, which provides convenience to measurement in insufficient light environment.

6. Measurement at input terminal

It is at the insertion port of the probe that the voltage, resistance, capacitance and other parameters are measured.

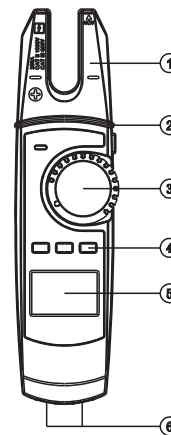

Figure 1

VI. Functions of Keys

SELECT: function selection button, which works at ACI/DCI, ACV/DCV, and RES/CNT/DIO/CAP gears.

1. Short press SELECT button at ACI/DCI gear to switch over ACI and DCI function.

When the rotary knob switches to ACI/DCI gear, it defaults to ACI function. Short press the SELECT button to switch to DCI function from ACI function; and short press the SELECT button again to switch to ACI function. The above forms a cycle.

2. Short press SELECT button at ACV/DCV gear to switch over ACV and DCV functions.

When the rotary knob switches to ACV/DCV gear, it defaults to ACV function. Short press SELECT button to switch to DCV function from ACV function and short press SELECT button again to switch to ACV function. The above forms a cycle.

3. Short press SELECT button at RES/CNT/DIO/CAP gear to switch over RES, CNT, DIO and CAP functions.

When the rotary knob switches to RES/CNT/DIO/CAP gear, it defaults to RES function. Short press SELECT button to switch to CNT function from RES function and short press SELECT button to switch to DIO function from CNT function; short press SELECT button to switch to CAP function from DIO function and short press SELECT button again to switch to RES function back from CAP function. The above forms a cycle.

REL: measure button of relative value, which works at other function gears except from CNT, DIO, NCV and DCI gears.

Short press REL button under normal measuring mode to switch to the relative value measuring mode. Under the relative value measuring mode, it will display Dn-Df on main display screen and display Df on sub display screen, of which Df is the last measured value (relative value) before pressing REL button and Dn is current measured value. Meanwhile, it will display "REL Δ" at the top left of the display screen, to indicate the entering of the relative value measuring mode.

Under REL mode, when short press REL button again, turn the rotary knob or press SELECT button for function shift, it will exit the relative value measuring mode and return to normal operation mode. Press HOLD button under the relative value measuring mode, it will enter the data-hold mode as well, and the clamp meter will not update the measurement data; when exit the relative value measuring mode, HOLD state will be cancelled as well.

ZERO: base reset button; this function is used with REL and works at DCI function gear.





Since the clamp head of the clamp meter generates the induced voltage due to earth magnetic field induction when it does not measure any signal, base number exists at DCI gear generally and varies from the placement position and direction of the clamp meter. It is necessary to deduct the base number at the time of DCI measurement.

Short press ZERO button under DC gear to enter the resetting mode and deduct the base number during DC measurement. Under the resetting mode, it will display Dn-Df on main display screen, of which Df is the DCI base number before pressing ZERO button, and Dn is current measured value. Meanwhile, it will display “ZERO” symbol at the top left of the display screen, to indicate the entering of the resetting mode at present.

If press ZERO function key again under the resetting mode, it will update Df again and display updated Dn-Df. If long press ZERO function key for over one second, or turn the rotary knob or press SELECT button for function shift, it can exit the reset function. Press HOLD button under the resetting mode, it will enter the data-hold mode as well, and the clamp meter will not update the measurement data; when exit the resetting mode, HOLD state will be cancelled as well.

HOLD: the data hold button, which works at all gears. Short press HOLD button under normal measurement mode, it will enter the data-hold mode, the clamp meter will not update the measurement data and the displayed value will be locked and remain unchanged. It will display “H” symbol at the top left of the display screen, to indicate the entering of the data-hold mode. Under the data-hold state, when short press HOLD button, or turn the rotary knob or press SELECT button for function shift, it can exit the data-hold function.

 : screen backlight control button, this function key can be used with HOLD button, and works when the clamp meter is on.

Under the backlight off state, long press  button to open the screen backlight and enter the low-light mode, under which the backlight brightness can meet the basis reading requirement, thus saving the battery capacity. Long press  button again to enter the high-light mode, under which the backlight brightness is higher and the screen contrast is clearer, thus increasing the battery capacity consumption accordingly. Long press  button again under the high-light mode, the backlight will be closed. The above forms a cycle. FLASHLIGHT  : LED lighting lamp on-off key, which works when the clamp meter is on. Short press LED lighting lamp to light it up, and short press FLASHLIGHT  key again to turn it off. The above forms a cycle.

VII. Technical Indexes

1. General specifications

Liquid crystal display: Maximum display up to 5999;
Polarity display: Automatic positive and negative polarity display;

Over-load display: Display in "OL" or "-OL";

Battery voltage display: When the battery voltage is low than 2.4V, it will display the low-voltage symbol;

Sampling rate: Approximately 3 times/second;

Sensor types: Hall effect sensor for DC/AC measurement;

Measured position error: When measuring the current, $\pm 1.0\%$ additional error may occur because it fails to put the source to be measured into the center position of the probe;

Impact-resistant strength: 1m height impact can be borne;

Maximum opening dimension of clamp head: Diameter of 14.7mm;

Predicted maximum dimension of the current wire: Diameter of 14.7mm;

Electromagnetic field effect: When the electromagnetic field interference exists, it probably displays unstable or incorrect readings;

Power requirements: Two AA 1.5V batteries;
Auto OFF function: 15 min;

Dimension: 210mm×53mm×35mm;

Weight: Approximately 163.7g (battery included);

2. Environmental limit

Working environment: Indoor use;

Altitude: <2,000 m;

Safety requirements: IEC61010-1; IEC61010-2-032;

CATII 1,000V; CATIII 600V;

Pollution degree 2;

Operating temperature and humidity: 0°C-30°C (not larger than 80%RH), 30°C-40°C (not larger than 75%RH), 40°C-50°C (not larger than 45%RH);

Storage temperature and humidity: -20°C-+60°C (not larger than 80%RH);

3. Electric specification

Accuracy: \pm (% reading + word count), calibration period is a year

Ambient temperature: 23°C \pm 5°C;

Ambient humidity: \leq 80%RH;

Temperature coefficient: 0.1 \times (accuracy)/°C;

(1). Measuring of AC current (A \sim)

ACI	Measurement Range	Resolution Ratio	Accuracy	Overload Protection
	200.0A	0.1A	$\pm(2.5\%+5)$	200A

Main display: true virtual value current;

Frequency response: 50Hz-60Hz;

(2). Measuring of DC current (A \rightleftharpoons)

DCI	Measurement Range	Resolution Ratio	Accuracy	Overload Protection
	200.0A	0.1A	$\pm(2.5\%+5)$	200A

DCI base number shall be cleaned up by pressing ZERO key.

(3). Measuring of AC voltage (\tilde{V})

	Measurement Range	Resolution Ratio	Accuracy	Overload Protection
ACV	6.000V	0.001V	$\pm(1.2\%+5)$	DC1000V /AC750V
	60.00V	0.01V	$\pm(1.2\%+3)$	
	600.0V	0.1V		
	750V	1V	$\pm(1.5\%+5)$	

Main display: true virtual value voltage;

Input impedance $\geq 10M\Omega$;

Frequency response: 45-400 Hz

(50-100Hz when $\leq 400mV$);

(4). Measuring of DC voltage (\bar{V})

	Measurement Range	Resolution Ratio	Accuracy	Overload Protection
DCV	6.000V	0.001V	$\pm(0.8\%+3)$	DC1000V /AC750V
	60.00V	0.01V		
	600.0V	0.1V		
	1000V	1V	$\pm(1.0\%+5)$	

Input impedance $\geq 10M\Omega$;

(5). Measuring of resistance (Ω)

	Measurement Range	Resolution Ratio	Accuracy	Overload Protection
RES	600.0 Ω	0.1 Ω	$\pm(1.2\%+2)$	DC1000V /AC750V
	6.000k Ω	0.001k Ω	$\pm(1.0\%+2)$	
	60.00k Ω	0.01k Ω		
	600.0k Ω	0.1k Ω		
	6.000M Ω	0.001M Ω	$\pm(1.2\%+2)$	
	60.00M Ω	0.01M Ω	$\pm(1.5\%+5)$	

(6). Conductivity testing (\rightarrow)

	Measurement Range	Resolution Ratio	Accuracy	Overload Protection
CNT	600.0 Ω	0.1 Ω	<10 Ω , the buzzer will ring >100 Ω , the buzzer will not ring	DC1000V /AC750V

Open-circuit voltage is about 1.2 V;

(7). Diode measurement (\rightarrow)

	Measurement Range	Resolution Ratio	Accuracy	Overload Protection
DIO	6.000V	0.001V	0.5V-0.8V	DC1000V /AC750V

Open-circuit voltage is about 3.3 V;

(8). Measuring of capacitance (\leftarrow)

	Measurement Range	Resolution Ratio	Accuracy	Overload Protection
CAP	60.00nF	0.01nF	$\pm(4.0\%+20)$	DC1000V /AC750V
	600.0nF	0.1nF		
	6.000 μ F	0.001 μ F		
	60.00 μ F	0.01 μ F	$\pm 10\%$	
	6.000mF	0.001mF		
	60.00mF	0.01mF	For reference only	

(9). Induced voltage measurement (NCV)

	Measurement Range	Accuracy
NCV	NCV	Induced voltage $\geq 100V_{rms}$; distance $\leq 10mm$ (LED flashes, and the buzzer alarms)

VIII. Measurement Operation

Instructions

⚠ Before measuring, it is necessary to ensure that the clamp meter has been switched to correct tap position. Measurement shall be in strict accordance with the guidance herein, and it is prohibited to switch the tap position during measurement, in order to avoid injury of users or damage of clamp meter.

1. Measuring of AC Current (ACI)

- (1) Set measuring function range of AC current
Rotate the knob to start up and keep the pointer directing to “A $\overline{\sim}$ ”; the clamp meter will be within the measuring function range of AC current as default;
- (2) Clamp instrument to input current signal to be tested
Clamp single current lead to be tested and keep it at the bottom of “U” clamp head. The clamp meter will automatically select the proper range and display the true virtual value of AC current at central screen. Frequency response range: 50Hz-60Hz.

⚠ Warning:
the largest measuring current shall not be greater than AC 200A during the measurement of AC current.

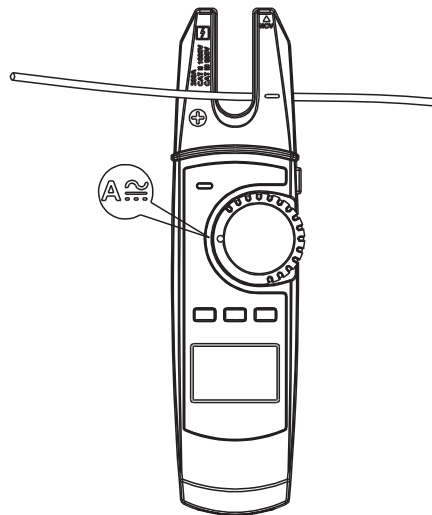

Figure 2

2. Measuring of DC Current (DCI)

- (1) Set measuring function range of DC current
Rotate the knob to start up and keep the pointer directing to “A $\overline{\text{A}}$ ”; the clamp meter will be within the measuring function range of DC current as default. Press the SELECT key to switch the clamp meter function into measuring function range of DC current;

- (2) Clear the base number of the measuring range of DC current

As the clamp head sensor reacts to terrestrial magnetism and surrounding magnetic field, there generally exists base number even without measuring. Therefore, before measuring DC current, base number shall be cleared by pressing “ZERO” key. Measurement shall be conducted after the base number is cleared and the measured value returns to zero;

- (3) Clamp instrument to input current signal to be tested
Clamp single current lead to be tested and keep it at the bottom of “U” clamp head. The clamp meter will automatically select the proper range. If the current direction is the same as that of clamp head, it will display the positive value of AC current at the central screen; otherwise, it will display the negative current value;

⚠ Warning:
the largest measuring current shall not be greater than DC 200A during the measuring of DC current.

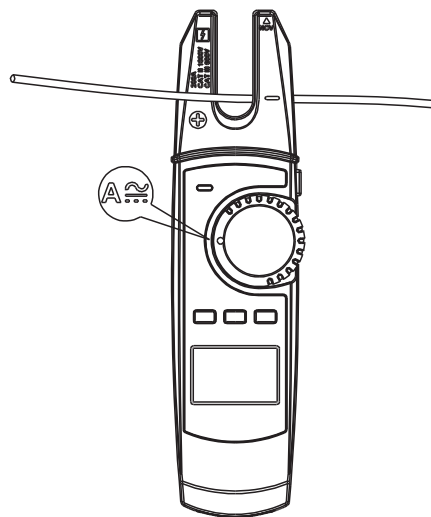

Figure 3

3. Measuring of AC Voltage (ACV)

(1) Insert meter probes

Insert the black probe into “COM” input end and insert the red probe into “V Ω” input end to prepare for the measurement;

(2) Set measuring function range of AC voltage
Rotate the knob to start up and keep the pointer directing to “V_{AC}”, and the clamp meter will be within the measuring function range of AC voltage as default;

(3) Connect voltage to be tested

Put red and black probes at two sides of voltage to be tested, and the clamp meter will automatically select the proper range. The central screen will display the current true visual value of AC voltage. When the voltage value exceeds AC 30V, the screen will display high-voltage alarm signal to warn against the shock hazard; frequency response scope: 45 Hz-400 Hz.

⚠ Warning:

AC voltage measuring range shall not be greater than AC 750 V;

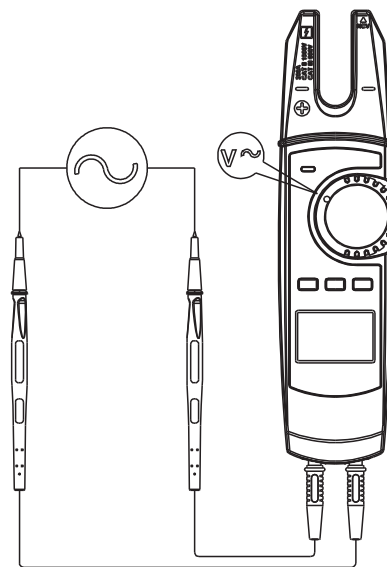

Figure 4

4. Measuring of DC Voltage (DCV)

(1) Insert meter probes

Insert the black probe into “COM” input end and insert the red probe into “VΩ” input end to prepare for the measurement;

(2) Set measuring function range of DC voltage

Rotate the knob to start up and keep the pointer directing to “V $\overline{\text{DC}}$ ”, will be within the measuring function range of DC voltage as default. Press the SELECT key to switch the clamp meter function into measuring function range of DC voltage;

(3) Connect voltage to be tested

Put red and black probes at two sides of voltage to be tested, and the clamp meter will automatically select the proper range. The central screen will display the current true virtual value of DC voltage; if the electric potential at red probe is higher than that at black probe, the screen will display the positive voltage value, otherwise the negative voltage value will be displayed; when the voltage exceeds DC 42V, the screen will display the high-voltage alarming sign to warn against the shock hazard.

⚠ Warning:

DC voltage measuring range shall not be greater than DC 1000V;

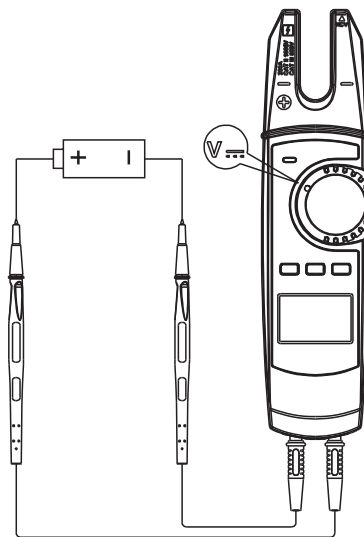

Figure 5

5.Measurement of Resistance (OHM)

(1) Insert meter probes

Insert the black probe into “COM” input end and insert the red probe into “VΩ” input end to prepare for the measurement;

(2) Set function range of resistance measurement

Rotate the knob to start up and keep the pointer directing to “Ω”, and the clamp meter will be within the measuring function range of resistance measurement as default;

(3) Connect resistance to be tested

Put red and black probes at two sides of resistance to be tested, the clamp meter will automatically select the proper range. The central screen will display the current resistance value;

⚠Warning:

during the measurement of connection resistance, the power must be cut off before connecting, and the residual electric charge of all capacitors shall be fully discharged. More accurate measurement may be available when the elements are separated from circuit.

⚠Note:

at the function range of 600Ω, it is suggested to firstly short-circuit the meter probe and press the REL key to clear the probe short circuit base number before measurement, to eliminate the impact of probe resistance.

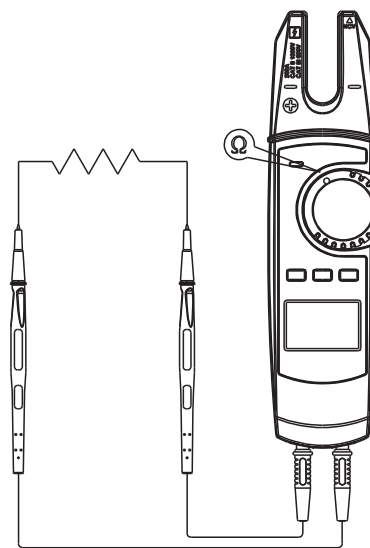

Figure 6

6. Conductivity Testing (CNT)

(1) Insert meter probes

Insert the black probe into “COM” input end and insert the red probe into “VΩ” input end to prepare for the measurement;

(2) Set function range of conductivity testing

Rotate the knob to start up and aim the pointer at “•||” , the clamp meter will be within the measuring function range of conduction testing as default. Press SELECT key to switch the clamp function into conductivity testing function range;

(3) Connect with the endpoints to be tested

Place the red and black probes at two sides of the endpoints to be tested. If the measured resistance is less than 10Ω , the buzzer will ring persistently; if it is between 10Ω and 100Ω , it may or may not ring; if it is larger than 100Ω , it will not ring.

⚠ Warning:

when measuring on-off condition, the circuit power must be cut off and the residual electric charge of all electric capacitors must be fully discharged before the endpoints are connected with the product.

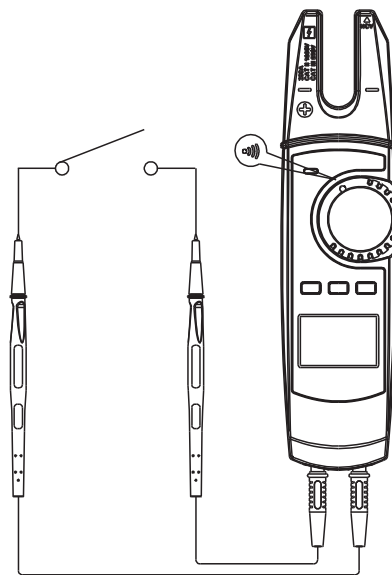

Figure 7

7. Diode Measurement (DIO)

(1) Insert meter probes

Insert the black probe into “COM” input end and insert the red probe into “VΩ” input end to prepare for the measurement;

(2) Set function range of diode measurement

Revolve the rotary knob to start up and aim the pointer at “▶”, and the clamp meter will be within the measuring function range of diode measurement as default. Press SELECT key to switch the clamp function into diode measurement function range;

(3) Connect with the diode to be tested

Place the red and black probes at positive and negative poles of the diode to be tested. The positive conductivity voltage value will be displayed in the center of the screen; if the probes are inserted in the wrong terminals, the screen shall display the measurement sign “OL”;

⚠ Warning:

when measuring the diode, the circuit power must be cut off and residual electric charge of all electric capacitors must be fully discharged before the diode is connected with the product. More accurate measurement may be available when the elements are separated from circuit.

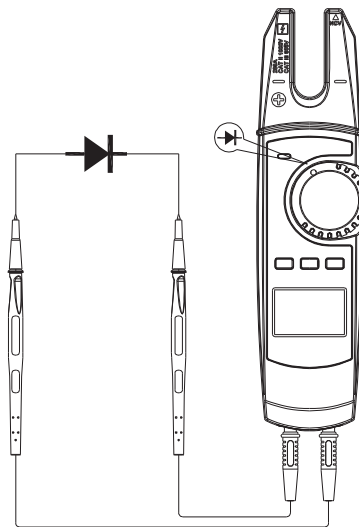

Figure 8

8. Measuring of Capacitance (CAP)

(1) Insert meter probes

Insert the black probe into “COM” input end and insert the red probe into “VΩ” input end to prepare for the measurement;

(2) Set function range of capacitance measurement

Rotate the knob to start up and keep the pointer directing to “ $\overline{1}$ ”; the clamp meter will be within the measuring function range of capacitance measurement as default. Press the SELECT key to switch the clamp meter function into measuring function range of capacitance measurement;

(3) Connect capacitance to be tested

Put red and black probes at two sides of capacitance to be tested, and the clamp meter will automatically select the proper range. The central screen will display the current capacitance measurement value;

⚠ Warning:

during the measurement of connection capacitance, the circuit power must be cut off and residual electric charge of all electric capacitors must be fully discharged before connecting. More accurate measurement may be available when the elements are separated from circuit. Before measuring the capacitance, REL key shall be pressed in advance to clean the open-circuit base number to eliminate the effect of probe parasitic capacitance.

⚠ Note:

at the range of 60nF, it is suggested to firstly press the REL key to clear the probe short circuit base number before measurement, to eliminate the impact of probe resistance.

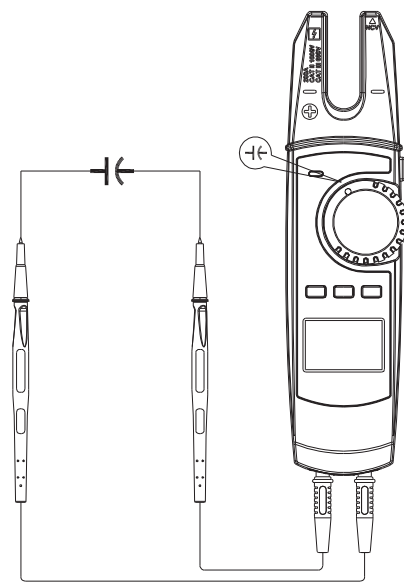

Figure 9

9. Measuring of Induced Voltage (NCV)

- (1) Set the measuring range of induced voltage
Rotate the knob to start up and keep the pointer directing to “NCV”, and the clamp meter will be within the measuring function range of induced voltage as default;

(2) Measuring of induced voltage

The top of right end of clamp head is equipped with electromagnetic induction sensor, which is able to detect whether the alternating current magnetic field exists or not. During the measurement, the right end of clamp head may be close to the tested conductor to conduct induction detection. The screen will display “EF” if the induced voltage is not detected. When the test distance is less than 10mm and the tested voltage is larger than 100Vrms, the clamp meter will alarm with buzz and NCV LED alarm light will also start to flicker. According to the magnitude of induced voltage, the central screen will display such four grades as “-”, “- -”, “- - -”, “- - - -”. The greater the induced voltage, the higher the grade displayed.

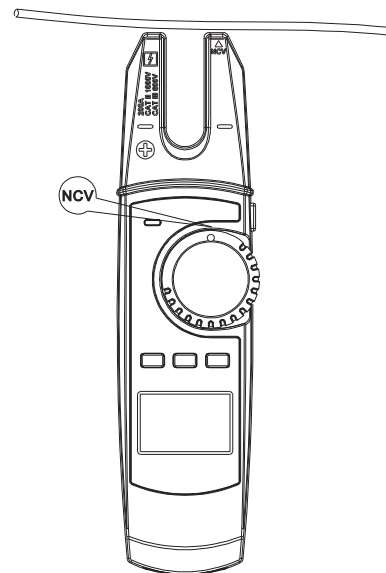

Figure 10

IX. Maintenance and Repair

⚠ Warning: please pull out the test probe before uncapping the lid so as to avoid electric shock.

1. General Maintenance

- a. The maintenance and other services of this clamp meter shall be accomplished by qualified professional maintenance staff or designated maintenance department.
- b. The shell shall be regularly cleaned by dry cloth. Detergent which contains abradant or solvent shall not be applied.

2. The installation or replacement of batteries

The power supply of this product is two AA 1.5V batteries. Please install or replace batteries according to the orders listed below:

- a. Turn off the product, and pull out the test probe which is at the input terminal.
- b. Turn the product's faceplate adown, unscrew the battery holder and remove the battery cover. Remove the batteries and install new batteries according to the polarity indication.
- c. Please use batteries of the same model, and don't install inappropriate batteries.
- d. After installing new batteries, fit on the battery cover, and lock the screws.

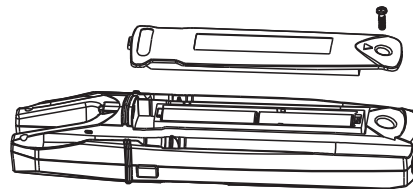

Figure 11

Instructions are subject to change without prior notice.

UNI-T®

UNI-TREND TECHNOLOGY (CHINA) CO., LTD.

No6, Gong Ye Bei 1st Road,
Songshan Lake National High-Tech Industrial
Development Zone, Dongguan City,
Guangdong Province, China
Tel: (86-769) 8572 3888
<http://www.uni-trend.com>